

DANEO 400

Technical Data



Technical Data

This technical data was extracted from the following manual: ENU 1040 05 11
© OMICRON electronics GmbH 2026. All rights reserved.

1 DANEO 400 technical data

1.1 Guaranteed values

The values are valid for the period of 1 year after factory calibration, within $23\text{ °C} \pm 5\text{ °C}$ at nominal value and after a warm-up time greater than 25 min.

The given input/output accuracy values relate to the range limit value (% of range limit value).

1.2 Power supply

Main power supply	
Connection	C14 connector according to IEC 60320-1
Voltage, single phase:	
Nominal voltage	100 ... 240 V AC
Operational range	85 ... 264 V AC
Power fuse	T 12.5 AH 250 V (5 × 20 mm) "Schurter", item number 0001.2515
Nominal current	10 A
Frequency:	
Nominal frequency	50/60 Hz
Operational range	45 ... 65 Hz
Overvoltage category	II

1.3 Analog measurement inputs

Analog inputs: ANALOG INPUT 1 ... 10	
Number of analog measurement inputs	10
Measurement ranges (RMS value of the sinusoidal shaped input signal)	10 mV, 100 mV, 1 V, 10 V, 100 V, 600 V
Crest factor	1.75
Sampling frequency	10 kHz 40 kHz
Input impedance	(1 M Ω \pm 2 %) (170 pF \pm 50 pF)
Measurement category	CAT II/600 V CAT III/300 V CAT IV/150 V
Temperature drift	< 25 ppm/K

1.3.1 Magnitude accuracy

The maximum measurement error is specified in percent (%) unit. The error is composed by 2 parts, the first one referring to the actual reading and the second one referring to the measurement range.

Maximum error				
Sampling frequency	10 kHz/40 kHz	10 kHz/40 kHz	10 kHz	40 kHz
Frequency range	DC	10 Hz ... 1 kHz	1 ... 4 kHz	1 ... 10 kHz
10 mV	0.08 + 0.50	0.20 + 0.30	0.20 + 0.30	0.20 + 0.30
100 mV	0.08 + 0.07	0.08 + 0.05	0.16 + 0.04	0.16 + 0.04
1 V	0.08 + 0.02	0.08 + 0.02	0.16 + 0.04	0.16 + 0.04
10 V	0.08 + 0.02	0.08 + 0.02	0.16 + 0.04	0.16 + 0.04
100 V	0.08 + 0.02	0.08 + 0.02	0.16 + 0.04	0.16 + 0.04
600 V	0.08 + 0.02	0.08 + 0.02	0.16 + 0.04	0.16 + 0.04

1.3.2 Phase and frequency accuracy

Phase and frequency accuracy are specified for signal levels above 10 % of range and sinusoidal signals. Phase and frequency accuracy are not guaranteed for the 10 mV range.

Accuracy of frequency and phase measurements			
Sample frequency	Frequency range	Maximum error	
		Frequency measurement	Phase measurement
10 kHz	15 ... 70 Hz	0.01 %	0.1 °
40 kHz	15 ... 70 Hz		

1.3.3 Power accuracy

The power measurement is specified for signal frequencies between 15 Hz and 70 Hz only. Errors are relative to actual measured values and specifications do not apply when one or both quantities are measured on the 10 mV or the 100 mV range.

Power measurement error			
Calculated quantity	Error	Relative magnitudes of measured quantities with respect to measurement range	Power factor limits
Apparent power S	0.24 %	$\geq 50 \%$	n. a.
	0.36 %	$\geq 20 \%$	
Active power P	0.30 %	$\geq 50 \%$	$ \cos(\varphi) \geq 0.5$
	0.42 %	$\geq 20 \%$	$(\varphi \leq 60^\circ, 120^\circ \leq \varphi \leq 180^\circ)$
Reactive power Q	0.30 %	$\geq 50 \%$	$ \cos(\varphi) \leq 0.866$
	0.42 %	$\geq 20 \%$	$(30^\circ \leq \varphi \leq 150^\circ)$

1.4 Harmonics

The first order harmonic (order 1, designated as f_1) is the fundamental component. Higher harmonic orders are 2 to 25.

There are 2 THD figures available, THDf and THDr, which are relative to the fundamental component and to the RMS value, respectively.

The THDf calculation conforms to the definitions in IEEE P1495, IEEE 519, and IEC 61000. The THDf may exceed 100 %. V_i and I_i are the magnitudes (RMS values) of the individual spectral components.

$$THDf = \frac{\sqrt{\sum_{i=2}^N V_i^2}}{V_1} \cdot 100\% \quad \text{or} \quad THDf = \frac{\sqrt{\sum_{i=2}^N I_i^2}}{I_1} \cdot 100\%$$

The THDr does not exceed 100 %. V_{rms} and I_{rms} are the “fast RMS” values of the harmonic calculation.

$$THDr = \frac{\sqrt{\sum_{i=2}^N V_i^2}}{V_{rms}} \cdot 100\% \quad \text{or} \quad THDr = \frac{\sqrt{\sum_{i=2}^N I_i^2}}{I_{rms}} \cdot 100\%$$

$$V_{rms} = \sqrt{\sum_{i=1}^N V_i^2} \quad \text{and} \quad I_{rms} = \sqrt{\sum_{i=1}^N I_i^2}$$

The maximum order (N) used in the calculations depends on several parameters such as nominal frequency and is always higher than the maximum order $i=25$ offered for acquisition and analysis.

The following table enumerates the harmonics accuracy where the error is derived from the harmonic calculation only. The measurement error for processed quantities such as voltages and currents (see section [Analog measurement inputs](#) (page 3)) is added to the harmonic accuracy error.

Harmonics accuracy		
Calculated quantity	Error	Conditions
Magnitudes (Order 1 ... 25)	0.1 % (of fundamental)	$f_1 = f_{nom}$ $15 \text{ Hz} \leq f_{nom} \leq 70 \text{ Hz}$
THD	0.2 %	THDf < 100 %
Magnitudes (Order 1 ... 9)	2.5 % (of fundamental)	$f_{nom} - 0.6 \text{ Hz} < f_1 < f_{nom} + 0.6 \text{ Hz}$ $50 \text{ Hz} \leq f_{nom} \leq 60 \text{ Hz}$
THD	2.5 %	THDf < 50 %

1.5 Binary inputs

Binary inputs: BINARY INPUT 1 ... 10		
Number of binary inputs		10
Number of potential groups		10
Trigger criteria		Potential-free (16 V even when device is not in run mode) or DC voltage compared to threshold voltage
Input ranges		10 V (–10 V ... 10 V); 100 V (–100 V ... 100 V); 600 V (–600 V ... 600 V) Default: 600 V
Sampling frequency		10 kHz
Time resolution		100 µs
Threshold:		
	Range	Same as selected input range; default: 18 V
	Resolution (input range)	100 mV (600 V); 10 mV (100 V); 1 mV (10 V)
	Error	Refer to section Analog measurement inputs (page 3).
Hysteresis		10 % of absolute value of threshold or 1 % of input range, whichever is higher. Pick-up value is threshold. Drop-off value is threshold minus hysteresis.
Deglitch time:		
	Range	0 ... 500 ms (refer to subsection Deglitching input signals (page 8)) Default: 0.5 ms
	Resolution	100 µs
Debounce time:		
	Range	0 ... 500 ms (refer to subsection Debouncing input signals (page 8)) Default: 1 ms
	Resolution	100 µs
Connectors		4 mm/0.16 " banana sockets on the front panel
Insulation		10 galvanic insulated binary inputs. Functional isolation with 4 mm creepage between channels. Reinforced insulation from all SELV interfaces and from power supply.
Data for potential-free operation		
Trigger criteria		Logical 0: $R > 80 \text{ k}\Omega$ Logical 1: $R < 20 \text{ k}\Omega$
Input impedance		$(125 \text{ k}\Omega \pm 20 \%) \parallel (170 \text{ pF} \pm 50 \text{ pF})$

Deglitching input signals

In order to suppress short spurious pulses a deglitching algorithm could be configured. The deglitch process results in an additional dead time and introduces a signal delay. In order to be detected as a valid signal level, the level of an input signal must have a constant value at least during the deglitch time. The figure below illustrates the deglitch function.

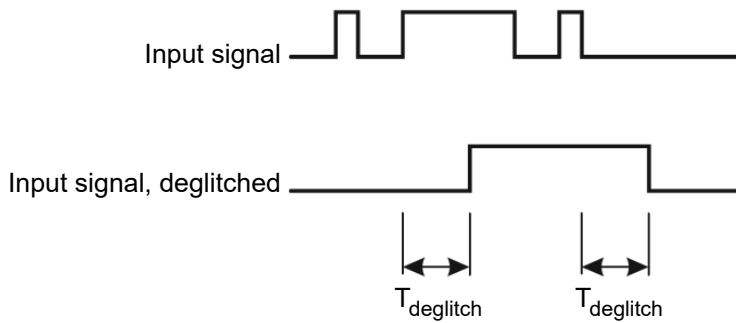

Debouncing input signals

For input signals with a bouncing characteristic, a debounce function can be configured. This means that the first change of the input signal causes the debounced input signal to be changed and then be kept on this signal value for the duration of the debounce time.

The debounce function is placed after the deglitch function described above and both are realized by the firmware of the *DANEO 400* and are calculated in real time.

The figure below illustrates the debounce function. On the right-hand side of the figure, the debounce time is too short. As a result, the debounced signal rises to “high” once again, even while the input signal is still bouncing and does not drop to low level until the expiry of another period T_{debounce} .

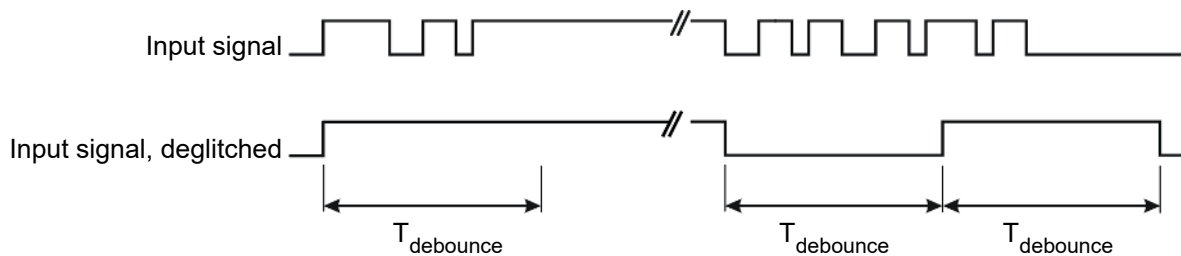

1.6 Binary outputs

Binary output relays: BINARY OUTPUT 1 ... 4	
Number of binary outputs	4
AC loading	$V_{\max} = 300 \text{ V AC}$ $I_{\max} = 8 \text{ A}$ $S_{\max} = 2\,000 \text{ VA}$
DC loading	$V_{\max} = 300 \text{ V DC}$ $I_{\max} = 8 \text{ A}$ $P_{\max} = 50 \text{ W}$ (refer to load limit curve)
Switch-on current	15 A (max. 4 s at 10 % duty cycle)
Electrical lifetime	100 000 switching cycles at 230 V AC/8 A and ohmic load
Pickup time	Approx. 6 ms
Fall back time	Approx. 3 ms
Bounce time	Approx. 0.5 ms
Connectors	4 mm/0.16 " banana sockets
Insulation	Reinforced insulation from all SELV interfaces and from power supply.

The following diagram shows the load limit curve for DC voltages. For AC voltages, a maximum power of 2 000 VA is achieved.

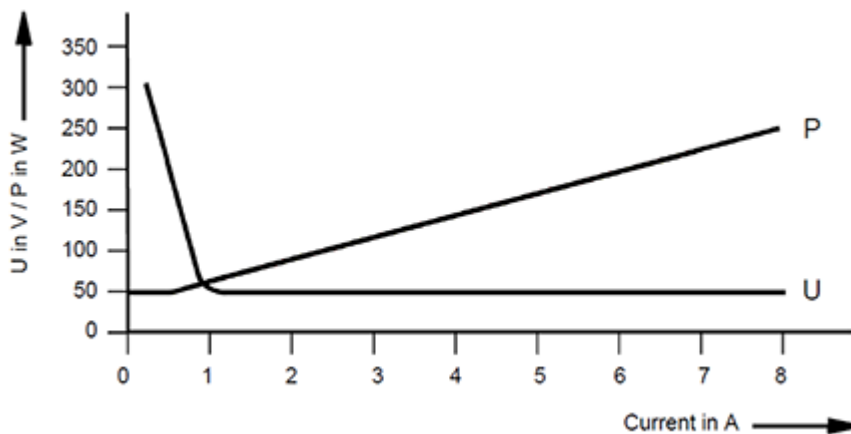

1.7 Ethernet ports

All Ethernet ports support Power over Ethernet (PoE) according to IEEE 802.3af and IEEE 802.3at. The accumulated output power of all PoE ports is limited to 75 W.

1.7.1 Control and network ports

Ethernet ports A, B, and ETH	
Type	10/100/1000Base-TX
Connector	RJ45
Cable type	LAN cable of category 5 (CAT5) or better
Status indication	Green indicator light: physical link present Yellow indicator light: traffic on port
Power over Ethernet (PoE)	IEEE 802.3af (PoE) and IEEE 802.3at (PoE+) compliant

1.7.2 Extension ports

Extension ports OUT 1 and OUT 2	
Type	100Base-TX
Connector	RJ45
Cable type	LAN cable of category 5 (CAT5) or better
Status indication	Green indicator light: physical link present Yellow indicator light: traffic on port
Power over Ethernet (PoE)	IEEE 802.3af (PoE) and IEEE 802.3at (PoE+) compliant

1.8 USB

1.8.1 Control port

Control port	
Type	USB 2.0 high speed (480 Mbit/s) USB 1.1 compatible (12 Mbit/s)
Power	4.5 W (5 V at 900 mA)
Connector	USB type B
Cable	< 5 m USB 2.0 high speed type A-B

1.8.2 Storage port

Storage port	
Type	USB 3.0 ultra speed (5 Gbit/s)
Connector	USB type A
Cable	Up to 900 mA

1.9 Environmental conditions

Environmental conditions	
Operating temperature ¹	0 ... +50 °C (+32 ... +122 °F)
Storage and transportation	-25 ... +70 °C (-13 ... +158 °F)
Maximum altitude:	
Operating	4 000 m (13 000 ft)
Non-operating	15 000 m (49 000 ft)
Humidity	5 ... 95 % relative humidity; no condensation

¹ In case of overtemperature, the *DANEO 400* switches off automatically. *DANEO Control* informs you that overtemperature has occurred (notification bar and message board) and what actions you can take to switch on the *DANEO 400*.

1.10 Mechanical data

Size, weight, and protection	
Dimensions W × H × D without handle	345 × 140 × 390 mm (13.58 × 5.51 × 15.35 ")
Weight	Approx. 7.0 kg (Approx. 15.4 lb)
Ingress protection	IP20 according to EN 60529

1.11 Electromagnetic compatibility and certified safety standards

EMC		
Emission:		
	Europe	EN IEC 61326-1; EN 61000-6-4; EN 61000-3-2/3
	International	IEC 61326-1; IEC 61000-6-4; IEC 61000-3-2/3
	USA	FCC Subpart B of Part 15 Class A
Immunity:		
	Europe	EN IEC 61326-1; EN 61000-6-2; EN 61000-4-2/3/4/5/6/11
	International	IEC 61326-1; IEC 61000-6-2; IEC 61000-4-2/3/4/5/6/11
Certified safety standards		
	Europe	EN 61010-1; EN IEC 61010-2-030
	International	IEC 61010-1; IEC 61010-2-030
	USA	UL 61010-1; UL 61010-2-030
	Canada	CAN/CSA-C22.2 No. 61010-1; CAN/CSA-C22.2 No. 61010-2-030
Certificates		 

Support

When you are working with our products, we want to provide you with the greatest possible benefits. If you need any support, we are here to assist you.



OMICRON Support – get in touch

micronenergy.com/support

At our support hotline, you can reach well-educated technicians for all of your questions.

Make use of our 24/7 hotlines:

Americas: +1 713 830-4660 or +1 800-OMICRON

Asia-Pacific: +852 3767 5500

Europe / Middle East / Africa: +43 59495 4444

Additionally, you can find the service center or sales partner closest to you at micronenergy.com.



OMICRON Customer Portal – stay informed

my.micronenergy.com

Browse through the knowledge library and find manuals, application notes, conference papers, and much more.

Download the latest software updates and learn about upcoming events.



OMICRON Academy – learn more

micronenergy.com/academy

Learn more about your product in one of the training courses offered by the OMICRON Academy.

UK importer:
OMICRON electronics UK Limited
Staples Close
Redhill Business Park
Stafford
ST16 1WQ
United Kingdom

Manufacturer:
OMICRON electronics GmbH
Oberes Ried 1
6833 Klaus
Austria