

Measurement, localization and monitoring of partial discharges on a power transformer

Power transformers, a key element of the electrical grid, are subjected to different levels of electrical, thermal, mechanical, and chemical stress during service. To ensure reliable and safe operation, it is key to assess the continuously aging insulation of the system during a transformer's life cycle. Partial discharge (PD) measurements are a non-destructive tool which allows for measurement, assessment, and localization of weak spots in complex insulation systems. PD measurements on power transformers are typically carried out during the manufacturing process as part of quality assurance, after onsite installation, and are used as a tool for condition-based maintenance for matured assets.

PD is a local electrical breakdown of a weak region within the electrical insulation system, resulting in fast current impulses. These electrical signals are often accompanied by other physical effects, such as pressure waves, electromagnetic signals, chemical effects or optical effects. [1] PD measurements of the different effects using conventional and unconventional tools and combining the findings will lead to a more meaningful assessment.

Case study – PD measurement on a 300 MVA oil-filled transformer

The high-voltage (HV) bushings of the 220 kV and the 110 kV windings had to be disassembled for the transportation of a 300 MVA transformer. After mounting the bushings at the new substation, the bushing domes had to be refilled with oil. Due to the horizontal-oriented bushings this had to be done very carefully to avoid gas bubbles. To ensure a proper filling, partial discharge (PD) measurements have been performed.

Fig. 1 shows the 300 MVA transformer with the horizontal 220 kV and 110 kV bushings and a small step-up transformer with 24/0.4 kV for exciting the 300 MVA transformer with a diesel-powered generator.



Figure 1
View of the 300 MVA Transformer

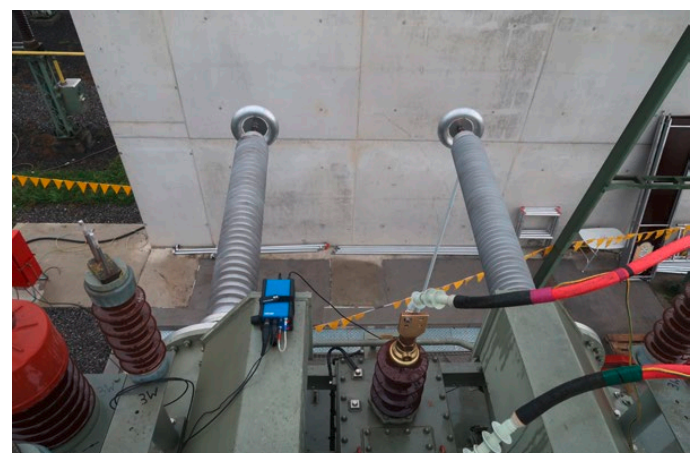

Figure 2
Setup for PD measurements on phases 1U and 1V

Electrical PD measurement

The test setup was performed in accordance with IEC 60270 [2], simultaneously decoupling the PD and AC signals at the measuring taps of all 220 kV and 110 kV bushings. Fig. 2 shows the setup of the MPD 800 PD detection instrument at the 220 kV bushings 1U and 1V. The signals of both bushing taps can be directly connected to one MPD 800 detector without using an additional coupling device. Fig. 3 shows the overall PD test setup.

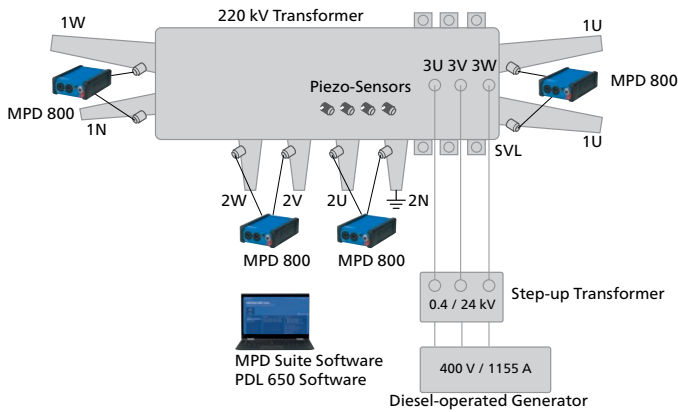

Figure 3
Setup for the PD measurements

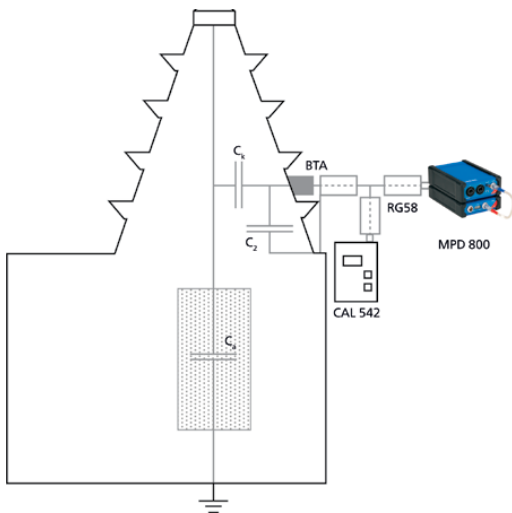

Figure 4
Artificial impulse injected directly at the bushing tap

A calibration signal was injected into all bushings, enabling the determination of a cross coupling matrix. In addition to the conventional PD calibration from HV to ground, a recording was also performed while injecting the calibrating signal into the measuring tap of the bushing to simulate a fault directly at the bushing tap. [1].

The ambient noise level was less than 10 pC at $0.5 \times U_n$ using a center frequency of 400 kHz and measuring bandwidth of 600 kHz. Even below the nominal voltage, partial discharges up to 2 nC could be detected at the measuring point 1U.

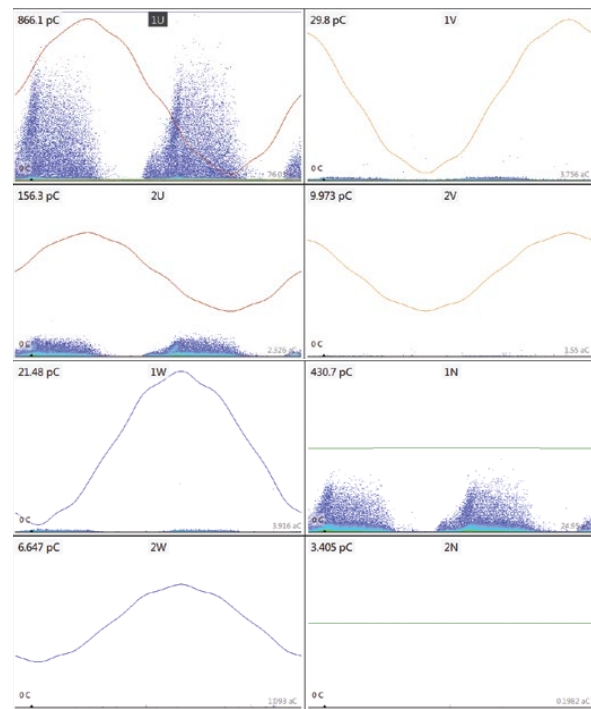

Figure 5
Phase Resolved PD (PRPD) pattern obtained at all measuring points at $0.8 \times U_n$, linear view

Comparing the charge values of the calibration cross coupling matrix with the cross coupling of the real PD activity indicated that the origin of the PD event is physically close to the measuring point 1U.

The MPD Suite software allowed the test engineers to draw a trigger window in the PRPD pattern. Only PD impulses occurring in the selected phase and amplitude area will trigger the scope and FFT view. This tool allows an easy comparison of the unfiltered high-frequency signals. Comparing the time signal and frequency spectrum of the signal directly injected at the bushing tap with the actual PD signal showed high similarities of their rise time and oscillation as well as resonances in the frequency spectrum. The frequency spectrum of the conventional calibration, where long cables had to be used, did not match.

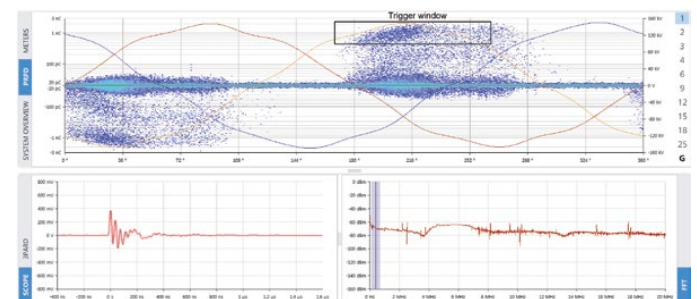

Figure 6
MPD Suite software; logarithmic-bipolar view of the PRPD pattern at 1U, the trigger window and corresponding time and frequency signal

Acoustic PD measurement and localization

The localization of PD sources is performed by means of differences in the runtime of the acoustic signal between the fault location and multiple acoustic emission (AE) sensors. Possible fault locations are calculated from the signal runtimes, using the speed of sound and the known geometrical positions of the sensors on the tank wall.

The MPD 800 PRPD window trigger also provides an electrical or optical output signal which can trigger an acoustical localization system. With this method the delay time to the different Piezo sensors can be measured absolutely referred to the electrical triggered PD impulse. This enables the use of averaging functions, which can result in a significantly improved signal-to-noise ratio. Fig. 7 shows the measured acoustic signals of the piezo sensors and the impact of averaging. The acoustic localization was performed with 8 piezo sensors installed in the area of phase 1U.

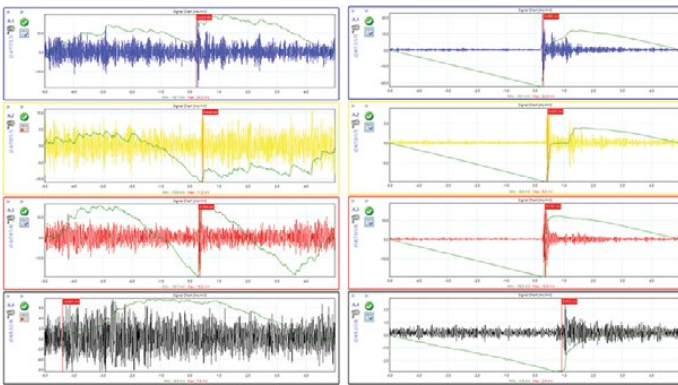

Figure 7
Acoustic signals without averaging (left) and the averaging of 100 events (right) using the electrical signal as trigger

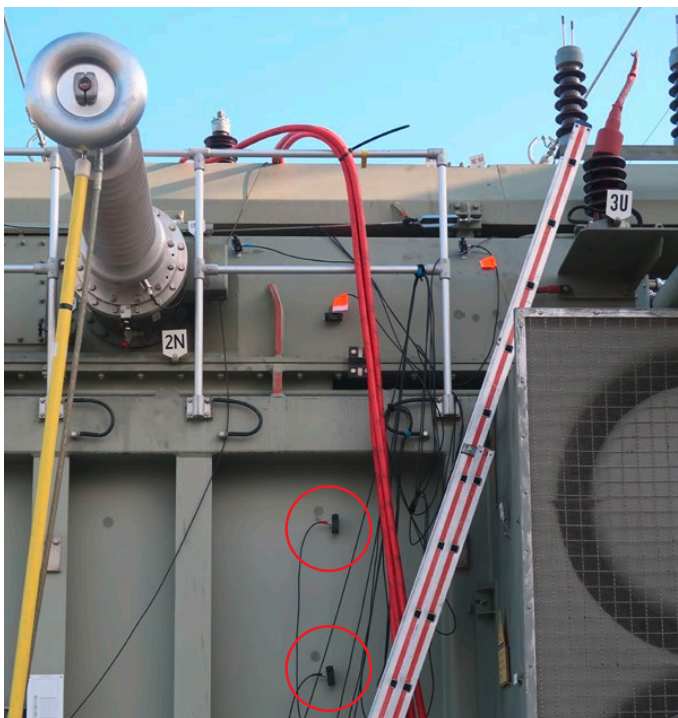

Figure 8
Installation of piezo sensors

The triangulated fault position as well as the acoustic signal of the internal partial discharges is shown in Fig. 9 and Fig. 10. The location is close to the high-voltage exit lead of the 220 kV winding of phase 1U.

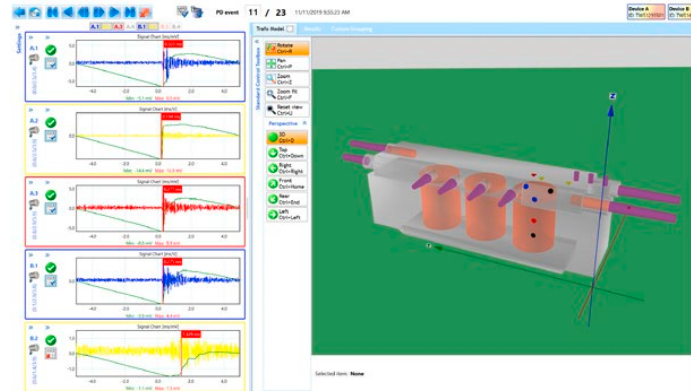

Figure 9
Acoustic signals of piezo sensors

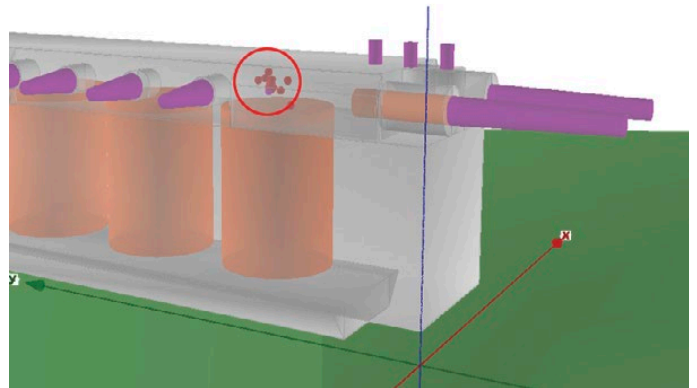

Figure 10
Location of PD at the high-voltage exit of phase 1U

Electrical PD Trending and Monitoring

Findings of the off-line PD measurement and localization were discussed with the transformer manufacturer. The fault location, PD behavior and the fact that it cannot be repaired on site led to the decision that the unit could be reenergized while carefully trending the PD activity as well as monitoring the gases dissolved in the insulation oil of the transformer.

The transformer was then therefore equipped with bushing adapters at the bushing taps of all 220 kV bushings. The MONTESTO 200 PD monitoring and trending device used can be remotely controlled and communicates with the control center in case PD warning levels are exceeded.

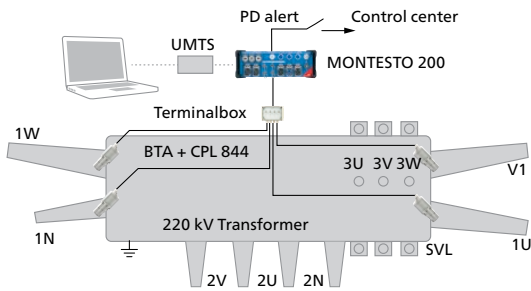

Figure 11
Complete setup of the PD monitoring and trending system

Audible corona discharge was active in the substation thus the measuring frequency was tuned to 2.2 MHz – a frequency range where the internal discharges dominated and external disturbances were minimized. The discharge level of the internal PD activity at Phase 1U was stable for the first weeks of operation, but then started to continuously increase over a period of one month. Fig. 12 shows the increasing trend of the apparent charge measured on Phase 1U.

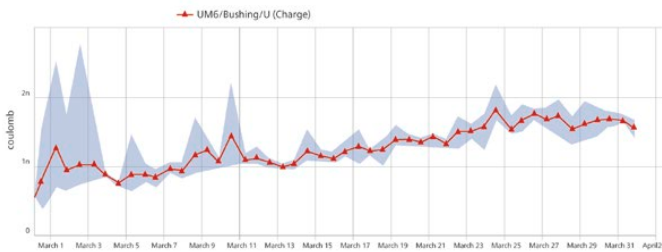

Figure 12
Increasing PD trend on Phase 1U

In addition to the known PD activity at Phase 1U a second pattern developed over 3 months, which started with approximately 100 pC and stabilized at 2 nC. The discharge pattern can be assigned to Phase 1V and shows high similarities to the phenomena obtained at 1U. The development of the PRPD pattern as well as the 3PARD diagram is shown in Fig. 13. Fig. 14 shows the development of the 3PARD filtered PRPD pattern obtained at Phase 1V.

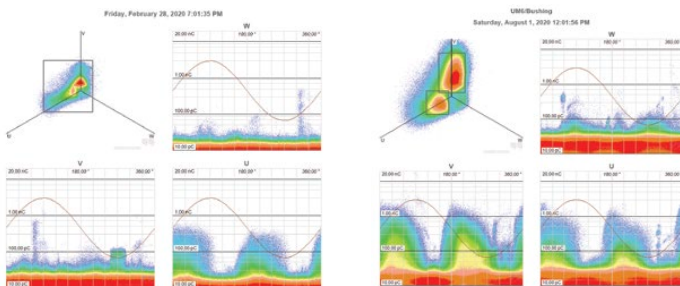

Figure 13
Development of PD activity over a period of 5 months, logarithmic view

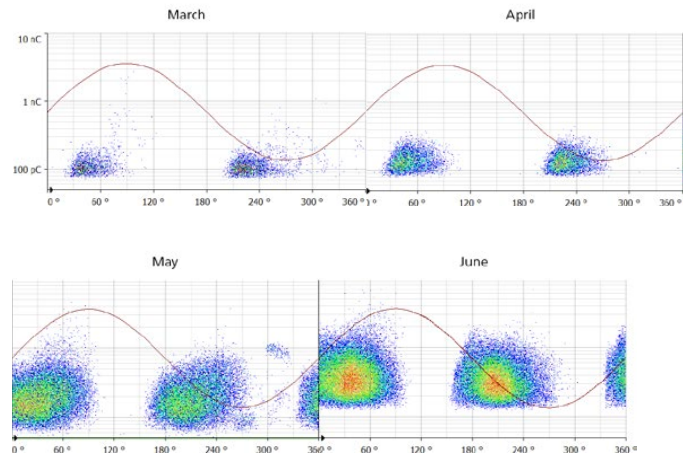

Figure 14
3PARD filtered PRPD pattern and development of the pattern obtained a Phase 1V

Dissolved Gas Analysis (DGA)

The DGA results before and after transportation did not indicate any failure nor PD activity. Hydrogen slightly increased during operation, but the overall amount of dissolved gases are below typical values, thus no reliable assessment can be performed [4]. A local defect inside a solid insulation part does not necessarily lead to an increase of dissolved gases.

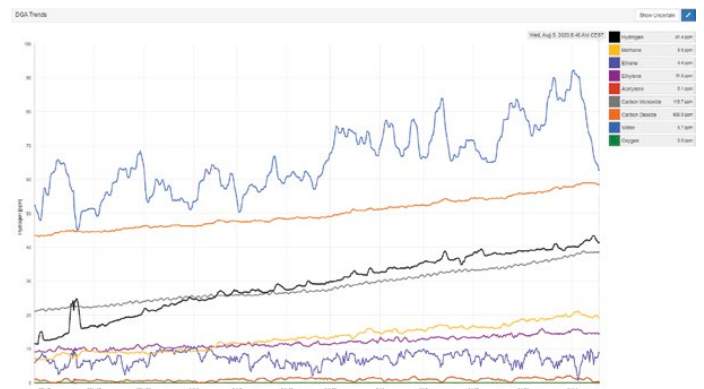

Figure 15
DGA trend over 3 months

Conclusion

In this article, the importance of electrical PD measurement, localization, monitoring and trending is discussed. On-site PD measurements on liquid-filled transformers are often only triggered by DGA results. The case study on the 300 MVA transformer highlights that an electrical PD measurement and trending can be more sensitive and instantaneous compared to the analysis of dissolved gases in oil. Analyzing the unfiltered signals in time and frequency domain as well as performing acoustical PD localization with three or more piezo sensors can provide valuable information when it comes to localization, interpretation and risk assessment. The transformer, with active but stable discharges in two phases remains online and will be further monitored.

References

1. CIGRÉ WG D1.29, Technical Brochure 676: Partial Discharges in Transformers
2. IEC 60270: Edition 3.1, 2015, High-voltage test techniques - Partial discharge measurements, International Electrotechnical Commission, Geneva, Switzerland
3. C57.127 (2007), IEEE Guide for the Detection and Location of Acoustic Emissions from Partial Discharges in Oil-Immersed Power Transformers and Reactors, The Institute of Electrical and Electronics Engineers, Inc. New York, USA, 2007
4. IEC 60599: Edition 3.0, 2015, Mineral oil-filled electrical equipment in service – Guidance on the interpretation of dissolved and free gases analysis

The authors

Udo Ranninger started working for OMICRON electronics in 2007. He is currently working as an application engineer focusing on partial discharge measurements after having had several different positions in the company. He graduated from the Institute of Higher Technical Education in Rankweil (Austria) in 2006, where he specialized in telecommunications and high-frequency technology.

udo.ranninger@omicronenergy.com



Michael Krüger works with OMICRON Energy in Klaus, Austria since 1999. After working as product manager and head of engineering services, he is now consulting engineer for "Testing and Diagnosis of Electric Power Equipment". He studied electrical engineering at the Technical University of Aachen (RWTH), the Technical University of Kaiserslautern (Germany) and graduated in 1976 (Dipl.-Ing.). In 1990 he received his PhD in electrical engineering from the Technical University of Vienna.

Michael Krüger has more than 40 years of experience in high-voltage engineering and testing and diagnosis on power and instrument transformers, rotating electrical machines, Gas-Insulated Switchgear (GIS) and power cables.

He has published more than 50 technical papers about electrical measurement on power and instrument transformers, rotating electrical machines, GIS and cables, and holds 15 patents. He is member of VDE for 40 years, Cigre and is a Senior Member of IEEE. He also works in several working groups of OEVE, IEC and Cigre.

michael.krueger@omicronenergy.com



OMICRON is an international company serving the electrical power industry with innovative testing and diagnostic solutions. The application of OMICRON products allows users to assess the condition of the primary and secondary equipment on their systems with complete confidence. Services offered in the area of consulting, commissioning, testing, diagnosis and training make the product range complete.

Customers in more than 160 countries rely on the company's ability to supply leading-edge technology of excellent quality. Service centers on all continents provide a broad base of knowledge and extraordinary customer support. All of this together with our strong network of sales partners is what has made our company a market leader in the electrical power industry.

For more information, additional literature, and detailed contact information of our worldwide offices please visit our website.

www.omicronenergy.com

Published in April 2021
Subject to change without notice.