

# Testing Solutions for Measurement Equipment

Power Quality Measurement Devices • Electricity Meters  
Measuring Transducers • Equipment Calibration



## The Challenge

The measurement of electrical quantities in a power system is one of the central tasks of every plant operator. For this purpose, current and voltage transformers supply the primary current and voltage values to measuring transducers, electricity meters and other measuring equipment. These measuring devices then forward the measured values by equivalent DC signals or via communication protocols to the data acquisition system. The measurement results provide the basis for system operation, for measuring the energy consumption for accounting purposes and also for more extensive analyses.

The requirements regarding the accuracy of the measured data depend on the specific purpose. Regular functional testing and calibration of the measuring devices are either prescribed by mandatory standards and regulations or form part of an established quality assurance concept. All types of measuring equipment, such as power quality measurement devices, electricity meters or transducers, can only be considered to provide valid measured values after prior calibration. This requires a comparison of the device against a precise and reliable signal source for current and voltage.

Functional and accuracy tests of measurement devices are not only necessary at the place of operation in an **electrical utility** or **industrial plant**. Precision tests are also carried out on measurement equipment at the **manufacturer's premises**, ranging from product development through type testing, certification and production testing to commissioning and handover to the end-user on site.

In the development and production process special requirements are often applied to the test equipment, which can include the interaction with other test devices or their integration into an automated test environment. In acceptance testing, decisive factors in the choice of this equipment include: reliability, efficiency, test automation, data transmission and documentation.

Engineers in electrical utilities and in industrial sites look for testing solutions that cover as many applications as possible and operate with software that is easy to handle. The wider their spectrum of tasks, the more extensive the application of the test equipment should be. Beyond the mere calibration of measuring instruments it should extend to all secondary equipment including the protection system.

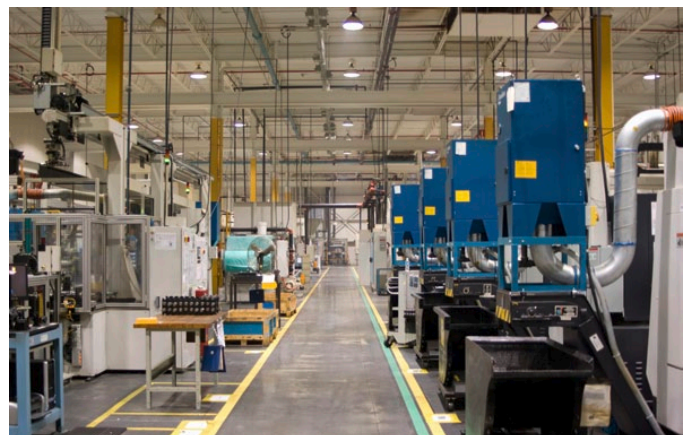

## The Solution

When using OMICRON test equipment, the combination of portable, reliable and precise hardware and powerful software guarantees that the best possible solution is available for the most challenging testing tasks.

### CMC 256plus

The CMC 256plus was developed as a high-precision multi-phase signal source and – together with the flexible operating software – sets the standard for testing and calibrating measuring instruments in electrical power systems. The unit can also be used for testing all types of protection equipment and therefore, covers the complete range of secondary equipment testing.

In addition to its versatility, the hardware of the CMC 256plus stands out due to its extremely high signal accuracy and long-term stability.

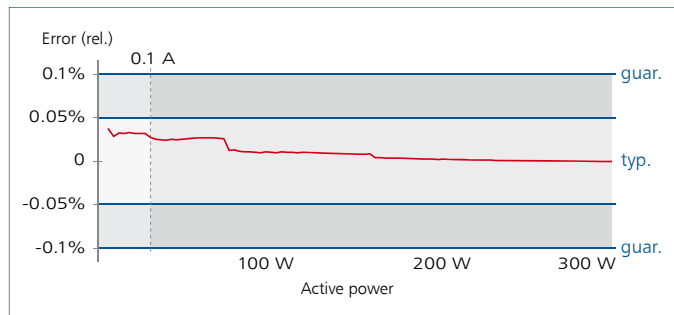

Measured output power accuracy of a CMC 256plus

The CMC 256plus is ideally suited for the calibration of electricity meters (4 quadrants, class 0.2), measuring transducers, power quality measurement devices (according to IEC 61000), phasor measurement units (PMU), various types of measuring equipment in SCADA systems, transient recorders or other measuring systems for electrical quantities such as voltage, current, frequency, power, etc.



### Features

- > Universal calibrator and protection test set in one unit
- > High precision, quality and reliability
- > Unique test functionality for manual and automatic testing, including the generation of complete test reports
- > Dedicated test modules tailored to power quality measurement devices, electricity meters and measuring transducers
- > Meter testing without an additional reference meter is possible, the signal sources represent the reference
- > Voltage and current outputs can be synchronized with an external or internal reference timer (typical error < 1  $\mu$ s)
- > Optional 10-channel analog measurement and transient recording functionality (EnerLyzer)

This brochure describes the use of OMICRON testing solutions for the following applications:

Testing Power Quality Measurement Devices .....	4
Testing Electricity Meters .....	5
Testing Measuring Transducers .....	6
Calibrating Measurement Equipment .....	6
Testing Phasor Measurement Units .....	7
Testing Merging Units .....	7
Measurements Using the CMC and EnerLyzer .....	7
Testing Current Transformers .....	7

## Testing Power Quality Measurement Devices

The increasing consumption of energy, the continuous extension of power grids and structural changes in power generation result in a higher susceptibility of the power systems to malfunctions or even large-scale failures. Additionally, some consumers can cause harmonics in the power system. Hence, signal quality has become an important issue for suppliers and customers because of the increasing sensitivity of electronic equipment and the high costs resulting from the loss of supply.

For this reason, the requirement for comprehensive power system quality monitoring is driving the development and installation of suitable measurement equipment. The working methods and the precision of the devices used for this purpose (classes A, S and B) are defined in the IEC 61000-4-30 standard. Attention is predominantly given to the voltage quality. However, there are also criteria relating to current such as, for example, harmonics or interharmonics.

Along with the use of new power quality measurement devices, the requirement arises to test their functionality and to verify their accuracy. Devices of class A put the highest demands on the accuracy of a test set. The test is usually performed on a three-phase basis since some quantities, such as voltage unbalance, can only be simulated with a three-phase source.

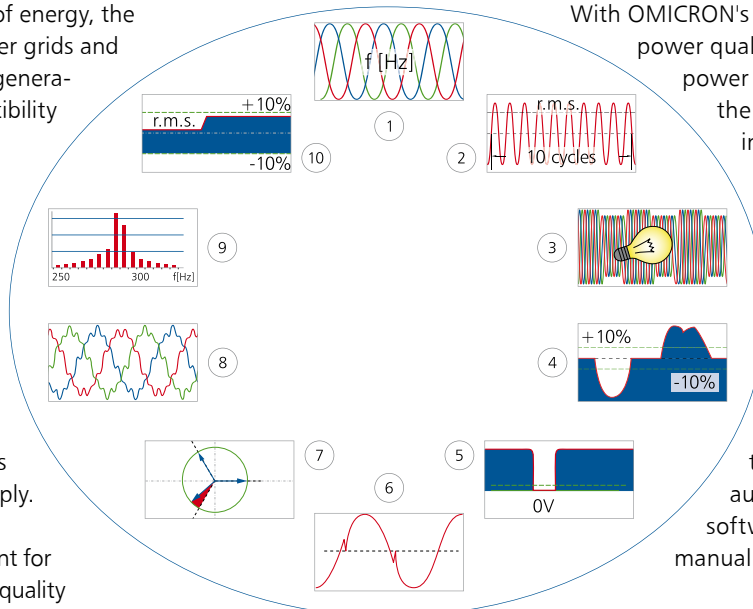

With OMICRON's tailored testing solution for power quality measurement devices the power quality parameters shown in the diagram can be integrated into a comprehensive test procedure. Statistical functions of power quality measurement devices can thereby be easily verified. Test points can be repeated any number of times or groups of test points can be processed in loops. If alarm contacts are available, the test can be performed automatically. Otherwise the software allows the input of manual assessment.

- 1... Power frequency
- 2... Magnitude of supply voltage
- 3... Flicker
- 4... Supply voltage dips and swells
- 5... Voltage interruptions
- 6... Transient voltages
- 7... Supply voltage unbalance
- 8... Voltage (current) harmonics
- 9... Voltage (current) interharmonics
- 10... Rapid voltage changes

Special requirements apply to type and certification tests such as the use of more complex, previously calculated transient signal shapes. An example is the consideration of the mutual influence of various power quality parameters (section 6 of IEC 61000-4-30: Range of influence quantities and steady-state verification). Furthermore it is necessary to integrate measured data utilizing specific data protocols from power quality measurement devices, performing automated nominal and actual value comparisons and synchronizing the input channels. With CM Engine, OMICRON provides an open data interface, allowing the development of individual test procedures for such specific applications with a maximum of flexibility for the user.

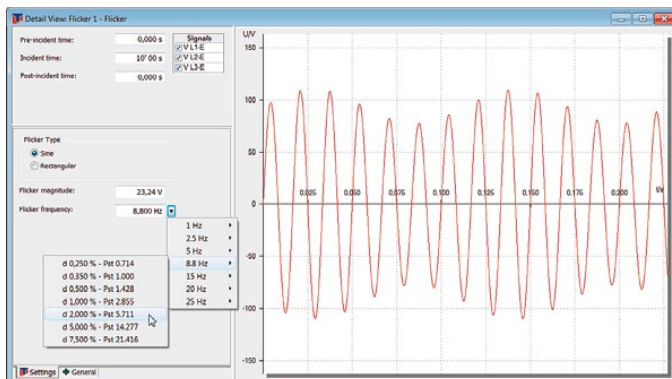

OMICRON's solution makes testing of power quality measurement devices quick and simple. It offers an ideal, portable alternative to conventional signal generators, which are normally only able to be used in the laboratory and not for mobile on-site testing in substations or power plants.

Software Module Power Quality Signal Generator:  
Detail View of a flicker state

## Testing Electricity Meters

In the field of electricity meter testing, OMICRON set a new standard many years ago. Tests can be performed without reference meters, because the voltage and current sources of the test set are so precise, that the testing device itself becomes the working reference. The substantially simplified test setup makes testing on-site much more convenient. Meanwhile this solution has become widely accepted and has proven to be reliable and efficient. The high stability of the voltage

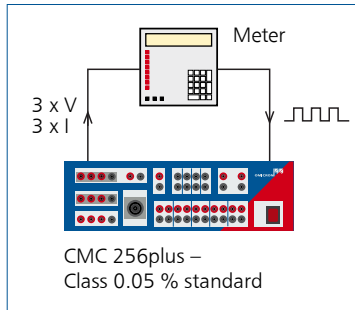

and current sources has been verified with measurements confirming the extremely low drift over a period of more than ten years. With cyclic calibration of the test set against a higher-level measurement reference, traceability to a national standard can be ensured.

For highly automated testing, the powerful Test Universe software running on a Windows PC is the ideal choice for operating the CMC 256plus. For quick manual testing, the test set can also be controlled via the flexible front panel control unit CMControl.

### Test Universe

The operating software offers various test modes such as load test, creep test, no-load test or counting mechanism test. Automated test sequences can be created with stop points to give instructions to the test engineer, e.g. for moving the pick-up head from one LED to the other. As a result, the software generates a table containing the error values and can also calculate the standard deviation if several tests are performed sequentially.

Each test point of the test table can be run in one of the following modes:

- > Load test: Accuracy of measurement unit (time power method)
- > Mechanism test: Accuracy of entire meter including display
- > Gated Mechanism test: Testing internal meter registers
- > Injection test Quick check: (wiring, sense of rotation)
- > No-load test: No start-up at zero load
- > Creep test: Start-up at low loads

Testing of the following meter functions is supported:

- > Wh importing/exporting
- > varh importing/exporting
- > I<sup>2</sup>h and V<sup>2</sup>h (load/no-load losses of transformers)
- > Qh (quantity hour)

### CMControl

For simple meter testing, the front panel control device CMControl provides a specific meter test tool. This includes the calibration of the Wh and varh measurements, each in both load directions. In combination with a CMC 256plus, the calibration of meters up to an accuracy class of 0.2 is possible. Start-up and no-load checks can also be performed to assess the proper function of all kind of meters.

### Accessories

OMICRON offers a comprehensive range of accessories to complete its meter test solutions. These include several designs of pick-up head for scanning the impulses from the meter. The following versions are offered:

- > With a mechanical holder for scanning the disks of electro-mechanical meters and the LEDs of electronic meters.
- > With a suction cup for all electronic meters with LED counter impulses. On rough or uneven surfaces, the uniquely small and lightweight pick-up head can alternatively be attached with a rubber adhesive material.
- > With a permanent ring magnet for scanning LED counter impulses, suitable for most electronic meters.

Users who are also responsible for other testing tasks in addition to meters e.g. protection, benefit additionally from the versatility of the CMC test sets.



CMC test set with scanning head. Operation via CMControl or Windows PC

## Testing Measuring Transducers

In high and medium voltage networks, measuring transducers form the basis of the system for recording electrical parameters such as voltage, current, frequency, phase angle, etc.. Switching operations or demands for additional power capacity via control centers are based on these measurements. In order to guarantee their measurement accuracy, periodical calibration of the measuring transducers distributed in nodes all over the power system is of extreme importance.

The CMC 256plus test set provides any desired electrical quantity with a maximum relative error typically less than 0.05 % (of the set value). Therefore, they are ideally suited for reliable calibration of electrical measuring transducers of all types, including the calibration of power transducers, which is very demanding with regard to the accuracy of the signal source.

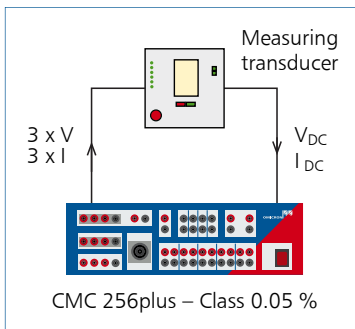

The operating software is tailored to these requirements and supports manual and automated testing of transducers with analog output signals of 0 - 10 V or 0 - 20 mA DC. The tests are performed using test tables with freely selectable test points. As a result, the software generates a test

report with graphs of the errors calculated from the nominal and actual value comparison over the complete measuring range.

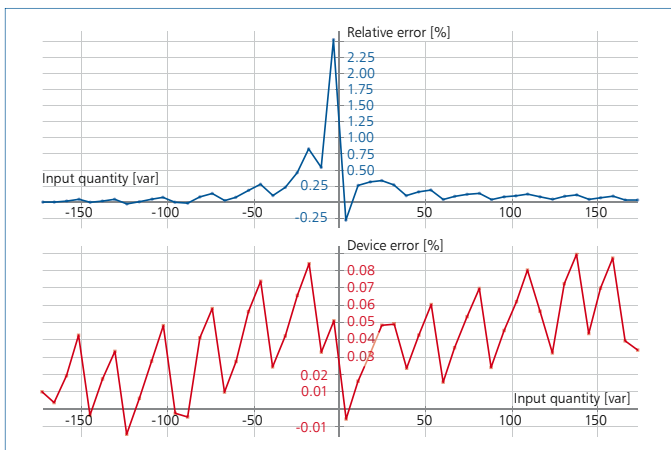

Error diagrams: % error across the measured value range

It is also possible to test transducers of more recent design types equipped with only a data interface or signal transmission lines with remote indication. For those cases, the measured values of the transducers are entered manually by the tester into the test point table of the software. Again, the errors are calculated and assessed automatically on the basis of the measurement results.

## Calibrating Measurement Equipment

Periodic calibration of in-house measurement equipment such as multimeters, power meters, current clamps, etc. is a standard procedure in many enterprises. If measurement equipment is calibrated in an external laboratory according to the organization's quality assurance specifications (usually based on ISO 9000), in addition to a considerable financial overhead, the equipment is often unavailable for long periods of times.

The CMC 256plus test set meets all the requirements for establishing an internal, cost-efficient and quick calibration service as an addition to the principal application of the unit. In those periods in which no routine tests are scheduled, it can be used for the calibration of such electrical measurement equipment, hence increasing its degree of utilization.

The functionality of the operating software for transducer testing is perfectly suited for such tasks. The user initially defines the test quantity, the range to be tested, the number of test points and the acceptable error tolerance in a manual test mode. During the actual test, the test engineer is guided through the process by the software and is prompted at each test point to enter the value read. As a result, the software generates a report which meets the usual requirements of quality assurance and contains the results in a tabular and graphic format.





## Testing Phasor Measurement Units

Conventional protection devices are designed to protect individual assets such as generators, transformers, transmission lines or busbars, for which locally measured values are usually sufficient. In contrast, network control systems with a system-wide view of the processes within the power system require dynamic information about power flows and the phase angles of the electrical quantities at various network nodes in order to safeguard the power system's stability. These measurement data can be provided by phasor measurement units (PMU) and open up new fields of application for network control under the concept of Wide Area Monitoring Protection & Control (WAMPC).

Testing of PMUs puts high demands on the test set's amplitude and phase accuracy described by the total vector error (TVE). Another

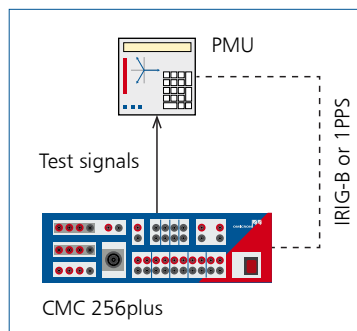

requirement is the synchronicity of the source and the PMU, which is established by time synchronization via GPS or IRIG-B. With GPS or IRIG-B add-on modules, synchronicity with a deviation of typically 1  $\mu$ s can be achieved when using a CMC test set for testing. In this case, the test signals are not only syn-

chronous at the start of the test (trigger) but are continuously kept synchronous by the time reference.

## Testing Merging Units

In substations designed according to the IEC 61850 communication standard, current and voltage values can be transmitted in digital format as Sampled Values from the instrument transformers to the secondary devices. Merging Units generate this data stream consisting of the Sampled Values of the measured quantities. The Merging Unit can obtain its input quantities from either conventional CTs and VTs, or Rogowski coils or other non-conventional instrument transformers.

A Merging Unit can be tested by applying conventional current and voltage signals to the unit under test using a CMC test set. The resulting Sampled Value data streams can subsequently be compared to the analog quantities of the test set, thereby verifying the amplitude and phase accuracy of the Merging Unit. As with the testing of PMUs, the synchronicity of the test set with the Merging Unit and the execution of static and dynamic tests is of paramount importance.

When used in IEC 61850 environments, OMICRON test sets can generate Sampled Values to stimulate the operation of IEDs (Intelligent Electronic Devices) such as protective relays or electricity meters. Additionally, the CMC can also produce and process GOOSE messages.

## Measurements Using the CMC and EnerLyzer™

By utilizing the EnerLyzer software option, the CMC 256plus can also be used as a multifunctional voltmeter, ammeter and transient recorder. In conjunction with EnerLyzer, the ten binary inputs of a CMC 256plus can become analog measurement inputs in five voltage ranges from 100 mV to 600 V. Currents can also be measured using current probes or shunts, making it possible to determine angle values,  $\cos \varphi$  and active, reactive and apparent power.

EnerLyzer offers the following measurement modes:

- > Multimeter functionality
- > Online harmonic analysis
- > Transient recording with various trigger criteria
- > Long-term trend recording



## Testing Current Transformers

The parameters of current transformers have a direct influence on the measuring accuracy of the overall system. With the CT Analyzer, OMICRON offers a unique solution for the efficient determination of the essential CT parameters including CT ratio, phase and current ratio errors for different burden values, the excitation curve, winding resistance, transient behavior, and many others. Due to its small size, low weight and high precision it is the perfect tool for CT testing both at the manufacturers' premises as well as on-site. The patented<sup>1</sup> measurement method allows very quick automated testing and reporting while ensuring the maximum level of operator safety.

For more information please refer to the CT Analyzer brochure (see last page).

<sup>1</sup> EP1653238 B1, EP1398644 B1, US6987390 B2

**OMICRON** is an international company serving the electrical power industry with innovative testing and diagnostic solutions. The application of OMICRON products allows users to assess the condition of the primary and secondary equipment on their systems with complete confidence. Services offered in the area of consulting, commissioning, testing, diagnosis and training make the product range complete.

Customers in more than 140 countries rely on the company's ability to supply leading edge technology of excellent quality. Service centers on all continents provide a broad base of knowledge and extraordinary customer support. All of this together with our strong network of sales partners is what has made our company a market leader in the electrical power industry.

The following publications provide detailed product information on the measurement solutions described in this brochure and on other secondary applications:



*CM Line product catalog  
(secondary equipment)*



*Testing Solutions for  
Protection Systems*



*CT Analyzer*

For a complete list of available literature please visit our website.

#### **Americas**

OMICRON electronics Corp. USA  
3550 Willowbend Blvd  
Houston, TX 77054, USA  
Phone: +1 713 830-4660  
+1 800-OMICRON  
Fax: +1 713 830-4661  
info@omiconusa.com

#### **Asia-Pacific**

OMICRON electronics Asia Limited  
Suite 2006, 20/F, Tower 2  
The Gateway, Harbour City  
Kowloon, Hong Kong S.A.R.  
Phone: +852 3767 5500  
Fax: +852 3767 5400  
info@asia.omicron.at

#### **Europe, Middle East, Africa**

OMICRON electronics GmbH  
Oberes Ried 1  
6833 Klaus, Austria  
Phone: +43 5523 507-0  
Fax: +43 5523 507-999  
info@omicron.at